

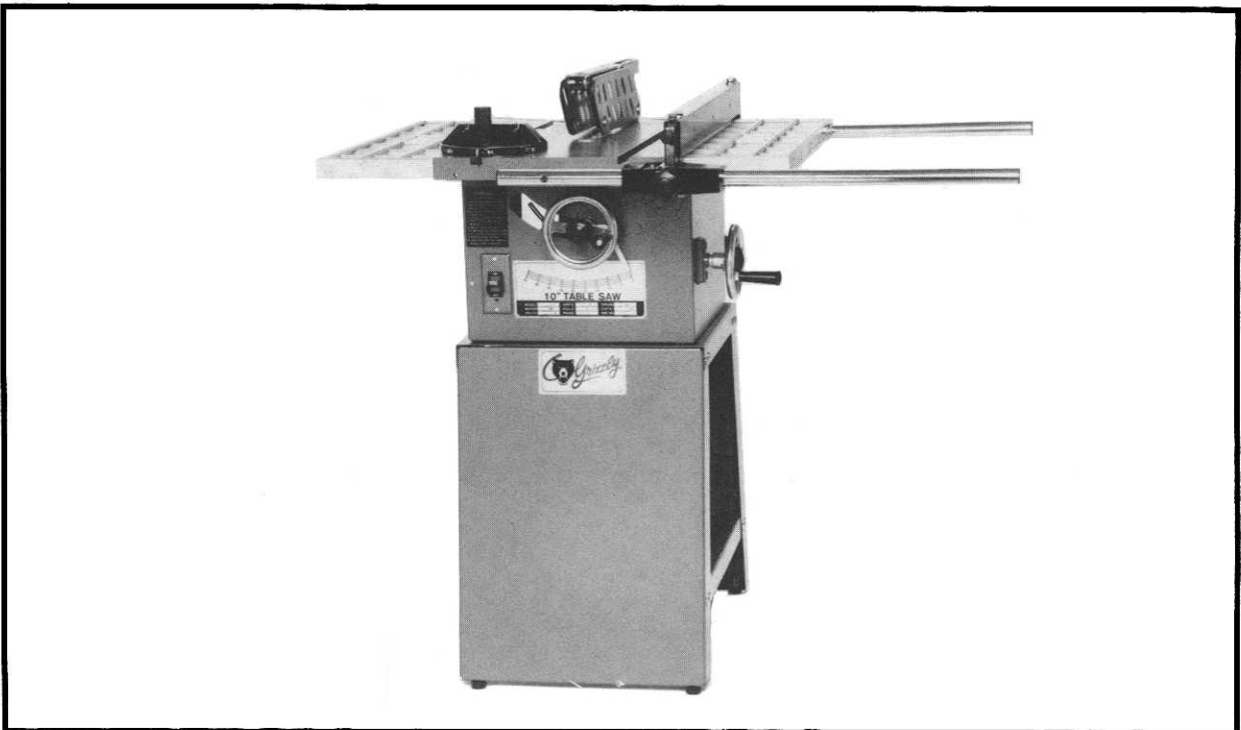

**10" TABLE SAW  
MODEL G1059  
INSTRUCTION MANUAL**



**GRIZZLY IMPORTS, INC.**

COPYRIGHT ©1994 BY GRIZZLY IMPORTS, INC.  
NO PORTION OF THIS MANUAL MAY BE REPRODUCED IN ANY SHAPE OR FORM  
WITHOUT THE WRITTEN APPROVAL OF GRIZZLY IMPORTS, INC.  
PRINTED IN USA FEBRUARY, 1994

# WARNING

Some dust created by power sanding, sawing, grinding, drilling, and other construction activities contains chemicals known to the State of California to cause cancer, birth defects or other reproductive harm. Some examples of these chemicals are:

- Lead from lead-based paints.
- Crystalline silica from bricks, cement, and other masonry products.
- Arsenic and chromium from chemically treated lumber.

Your risk from these exposures varies, depending on how often you do this type of work. To reduce your exposure to these chemicals: work in a well ventilated area, and work with approved safety equipment, such as those dust masks that are specially designed to filter out microscopic particles.

# WOODWORKING EQUIPMENT SAFETY INSTRUCTIONS

## WARNING

### For Your Own Safety Read Instruction Manual Before Operating This Equipment

Woodworking can be fun and rewarding, however it can also be a dangerous activity if safe and proper operating procedures are not followed. Please take the time to review the manual which was supplied with your machine, as well as these general safety instructions. Make sure you have properly assembled and adjusted the machine before operating it the first time. Also make certain you understand the procedures you are going to perform. Thinking through the steps or going through the motions of the operation with the machine off is often a good way to anticipate potential problems. Always use common sense and exercise caution in the workshop. If a procedure feels dangerous or awkward, don't do it!

If the instruction manual does not answer your questions, or you cannot find assistance from other woodworking books or references, please contact Grizzly Industrial's Customer Service:

Grizzly Industrial, Inc.  
1203 Lycoming Mall Circle  
Muncy, PA 17756  
Phone: (570) 546-9663  
Fax: 1-800-438-5901  
E-Mail: [techsupport@grizzly.com](mailto:techsupport@grizzly.com)  
Web Site: <http://www.grizzly.com>

## WARNING

### Safety Instructions For Power Tools

1. **KEEP GUARDS IN PLACE** and in working order.
2. **REMOVE ADJUSTING KEYS AND WRENCHES.** Form a habit of checking to see that keys and adjusting wrenches are removed from tool before turning on.
3. **KEEP WORK AREA CLEAN.** Cluttered areas and benches invite accidents.
4. **DO NOT USE IN DANGEROUS ENVIRONMENT.** DO NOT use power tools in damp or wet locations, or where any flammable or noxious fumes may exist. Keep work area well lighted.
5. **KEEP CHILDREN AND VISITORS AWAY.** All children and visitors should be kept a safe distance from work area.
6. **MAKE WORK SHOP CHILD PROOF** with padlocks, master switches, or by removing starter keys.
7. **DO NOT FORCE TOOL.** It will do the job better and safer at the rate for which it was designed.
8. **USE RIGHT TOOL.** DO NOT force tool or attachment to do a job for which it was not designed.

# WARNING

## Safety Instructions For Power Tools

9. **USE PROPER EXTENSION CORD.** Make sure your extension cord is in good condition. Conductor size should be in accordance with the chart below. The amperage rating should be listed on the motor or tool nameplate. An undersized cord will cause a drop in line voltage resulting in loss of power and overheating. Your extension cord must also contain a ground wire and plug pin. Always repair or replace extension cords if they become damaged.

Minimum Gauge for Extension Cords

AMP RATING	LENGTH		
	25ft	50ft	100ft
0-6	16	16	16
7-10	16	16	14
11-12	16	16	14
13-16	14	12	12
17-20	12	12	10
21-30	10	10	No

10. **WEAR PROPER APPAREL.** DO NOT wear loose clothing, gloves, neckties, rings, bracelets, or other jewelry which may get caught in moving parts. Non-slip footwear is recommended. Wear protective hair covering to contain long hair.
11. **ALWAYS USE SAFETY GLASSES.** Also use face or dust mask if cutting operation is dusty. Everyday eyeglasses only have impact resistant lenses, they are NOT safety glasses.
12. **SECURE WORK.** Use clamps or a vise to hold work when practical. It's safer than using your hand and frees both hands to operate tool.
13. **DO NOT OVERREACH.** Keep proper footing and balance at all times.
14. **MAINTAIN TOOLS WITH CARE.** Keep tools sharp and clean for best and safest performance. Follow instructions for lubricating and changing accessories.
15. **USE RECOMMENDED ACCESSORIES.** Consult the owner's manual for recommended accessories. The use of improper accessories may cause risk of injury.
16. **REDUCE THE RISK OF UNINTENTIONAL STARTING.** On machines with magnetic contact starting switches there is a risk of starting if the machine is bumped or jarred. Always disconnect from power source before adjusting or servicing. Make sure switch is in OFF position before reconnecting.
17. **MANY WOODWORKING TOOLS CAN "KICKBACK" THE WORKPIECE** toward the operator if not handled properly. Know what conditions can create "kickback" and know how to avoid them. Read the manual accompanying the machine thoroughly.
18. **CHECK DAMAGED PARTS.** Before further use of the tool, a guard or other part that is damaged should be carefully checked to determine that it will operate properly and perform its intended function. Check for alignment of moving parts, binding of moving parts, breakage of parts, mounting, and any other conditions that may affect its operation. A guard or other part that is damaged should be properly repaired or replaced.
19. **NEVER LEAVE TOOL RUNNING UNATTENDED. TURN POWER OFF.** DO NOT leave tool until it comes to a complete stop.
20. **NEVER OPERATE A MACHINE WHEN TIRED, OR UNDER THE INFLUENCE OF DRUGS OR ALCOHOL.** Full mental alertness is required at all times when running a machine.

### CAUTION

No list of safety guidelines can be complete. Every shop environment is different. Always consider safety first, as it applies to your individual working conditions. Use this and other machinery with caution and respect. Failure to do so could result in serious personal injury, damage to equipment or poor work results.

# TABLE OF CONTENTS

<b>I. INTRODUCTION</b> .....	1
<b>II. COMMENTARY</b> .....	1
<b>III. SAFETY RULES FOR ALL TOOLS</b> .....	2
<b>IV. UNPACKING</b> .....	4
<b>V. PIECE INVENTORY</b> .....	4
<b>VI. CLEANUP</b> .....	5
<b>VII. ELECTRICAL SERVICE REQUIREMENTS</b> .....	6
A. CIRCUIT LOADING .....	6
B. GROUNDING .....	6
C. GENERAL INFORMATION .....	6
D. 220 VOLT OPERATION .....	6
E. WORD OF CAUTION .....	7
<b>VIII. ASSEMBLY</b> .....	7
A. TOOLS REQUIRED .....	8
B. STAND .....	8
C. MOUNTING TABLE SAW UNIT TO STAND .....	9
D. HAND WHEELS .....	10
E. MOTOR, PULLEY AND V-BELT .....	10
F. EXTENSION WINGS .....	13
G. GUIDE RAILS AND FENCE .....	13
H. BLADE INSTALLATION .....	14
I. BLADE GUARD AND SPLITTER .....	15
J. TABLE INSERT .....	16
<b>IX. CONTROLS AND ADJUSTMENTS</b> .....	17
A. FENCE ADJUSTMENT .....	17
B. BLADE ADJUSTMENT .....	19

C. 45° AND 90° POSITIVE STOPS .....	20
D. WORM GEAR MECHANISM .....	21
E. POINTER .....	21
F. MITER GAUGE .....	22
G. HAND WHEELS .....	22
<b>X. TABLE SAW SAFETY .....</b>	<b>22</b>
<b>XI. OPERATING PROCEDURES .....</b>	<b>24</b>
A. TEST RUN .....	24
B. RIPPING .....	24
C. CROSSCUTTING .....	25
D. OTHER USES.....	26
<b>XII. MAINTENANCE ITEMS .....</b>	<b>26</b>
A. LUBRICATION .....	26
B. V-BELT .....	26
C. TABLE MAINTENANCE .....	27
D. MISCELLANEOUS .....	27
<b>XIII. CLOSURE .....</b>	<b>27</b>
<b>XIV. MACHINE DATA .....</b>	<b>28</b>
<b>XV. PARTS LIST—BODY, TABLE &amp; FENCE .....</b>	<b>29</b>
<b>XVI. PARTS DIAGRAM—BODY, TABLE &amp; FENCE.....</b>	<b>30</b>
<b>XVII. PARTS LIST—INTERNAL .....</b>	<b>31</b>
<b>XVIII. PARTS DIAGRAM—INTERNAL.....</b>	<b>32</b>
<b>XIX. STAND PARTS LIST &amp; DIAGRAM.....</b>	<b>33</b>
<b>XX. TROUBLESHOOTING .....</b>	<b>34</b>
<b>XXI. WARRANTY AND RETURNS .....</b>	<b>35</b>

# I. INTRODUCTION

Grizzly Imports, Inc., is proud to bring you the Model G1059 10" Table Saw. The Model G1059 is part of Grizzly's large family of fine woodworking machinery. When used according to the guidelines set forth in this manual, you can expect years of trouble-free, enjoyable operation and proof of Grizzly's commitment to customer satisfaction.

The Model G1059 10" Table Saw is designed for light-to-medium duty use by contractors or small shop owner. Its compact design and relatively light weight make it sturdy, yet quite portable. The G1059 features a solid cast iron table with cast aluminum wings, a 1½ HP motor, steel A-frame type stand, and a front-and-rear locking rip fence for accurate cuts.

We are also pleased to provide this instruction manual with the Model G1059 Table Saw. This instruction manual was written to guide you through assembly, review safety considerations and cover general operating procedures. It represents our latest effort to produce the best documentation possible. If you have any suggestions, or comments that you feel we should include in our next printing, please write to us at the address below.

Manager, Technical Documentation  
Grizzly Imports, Inc.  
P.O. Box 2069  
Bellingham, WA 98227-2069

Finally, we stand behind our machines. We have two excellent regional service departments at your disposal, should the need arise. If you have any service questions or parts requests, please call or write to us at the appropriate location listed below.

**If you live West of the  
Mississippi River, contact:**  
P.O. Box 2069  
Bellingham, WA 98227  
Phone: (206) 647-0801  
FAX: (800) 225-0021

**If you live East of the  
Mississippi River, contact:**  
2406 Reach Road  
Williamsport, PA 17701  
Phone: (717) 326-3806  
Fax: (800) 438-5901

# II. COMMENTARY

As with any tool or machine, a complete understanding of how this machine operates is necessary for safe operation. Take time to read this manual thoroughly. If you don't understand something, **DO NOT** operate this machine. Contact us first for assistance or advice. Grizzly cautions that although our Safety Rules are extensive, they aren't necessarily comprehensive. The bottom line on safety is this: Make sure a setup or operation is safe *as it applies to your situation*.

The specifications, drawings and photographs in this manual represent the Model G1059 as supplied when this manual was prepared. We are meticulous with our manuals; however, product changes or discrepancies can occur. Whenever possible, we send manual updates to all owners of a particular tool or machine. Should you receive one, please insert the new information with the old and keep it for reference.

We recommend you keep a copy of our current catalog for complete information regarding Grizzly warranty and return policy. Should you need additional technical information in regard to this machine, or if you need general assistance or parts, please contact the appropriate regional service department.

### III. SAFETY RULES FOR ALL TOOLS

There is a certain amount of danger associated with the use of this tool. Operating it with respect and caution will considerably reduce the possibility of personal injury. If safety precautions are ignored, injury to the operator or others in the area can occur.

There are certain applications for which this tool was designed. We strongly emphasize that this tool never be modified and/or used for any application other than that for which it was intended. Modifications and/or improper use of this tool will void all warranties.

The following are important safety rules for all tools:

1. **KNOW YOUR POWER TOOL.** Read the owner's manual carefully. Learn the tool's capabilities and limitations, as well as the specific potential hazards associated with it.
2. **KEEP ALL GUARDS IN PLACE** and in working order.
3. **GROUND ALL NON-INSULATED TOOLS.** If tool is equipped with a three-prong plug, it should be plugged into a grounded three-hole electrical receptacle. If an adapter is used to accommodate a two-prong receptacle, the adapter plug must be attached to a known ground. Never remove the grounding prong from the plug.
4. **REMOVE ADJUSTING KEYS AND WRENCHES.** Develop the habit of checking to see that keys and adjusting wrenches are removed from the tool before turning it on.
5. **KEEP WORK AREA CLEAN.** Cluttered areas and benches invite accidents.
6. **AVOID DANGEROUS ENVIRONMENTS.** Do not use power tools in damp or wet locations, or expose them to rain. Keep work area well lighted.
7. **KEEP CHILDREN AND VISITORS AWAY.** All children and visitors should be kept a safe distance from the work area.
8. **MAKE WORKSHOP CHILD-PROOF.** Use padlocks, lockable master switches, or remove starter keys.
9. **DO NOT FORCE MATERIAL INTO THE TOOL.** It will do the job better and be safer at the rate for which it was designed.



10. **USE THE RIGHT TOOL.** Don't use a tool or attachment to do a job that it was not designed to do.
11. **WEAR PROPER APPAREL.** Don't wear loose clothing, gloves, neckties or jewelry which might get caught in moving parts. Non-skid footwear is also recommended. Wear a hat or hair covering to contain long hair.
12. **USE SAFETY GLASSES AND EAR PROTECTION.** Also, use a dust mask or respirator if tool produces dust during operation.
13. **SECURE WORK.** Use clamps or a fixture to hold workpiece. It is safer than using your hand and frees both hands to operate the tool.
14. **DO NOT OVERREACH.** Keep proper footing and balance at all times.
15. **MAINTAIN TOOLS IN TOP CONDITION.** Keep cutting tools sharp and clean for best and safest performance. Follow instructions for lubricating and changing accessories.
16. **DISCONNECT TOOLS** from power source and wait for all moving parts to stop before inspecting for problems, servicing and when changing accessories such as blades, bits and cutters. When in doubt, pull the plug.
17. **USE RECOMMENDED ACCESSORIES.** Refer to the current catalog for recommended accessories. The use of improper accessories may be hazardous.
18. **AVOID ACCIDENTAL STARTING.** Make sure switch is in the "OFF" position before plugging in power cord.
19. **NEVER STAND OR LEAN ON TOOL.** Serious injury could occur if the tool is tipped or if the cutting surface is accidentally contacted.
20. **CHECK FOR DAMAGED PARTS.** Before further use of tool, any part that is damaged should be repaired or replaced. Check for alignment of moving parts, binding of moving parts, broken parts, mounting and any other conditions that may affect tool operation. Inspect equipment often, and service promptly when necessary.
21. **DIRECTION OF FEED.** Feed work into a blade or cutter against the direction of rotation of the blade or cutter only.
22. **NEVER LEAVE TOOL RUNNING UNATTENDED — TURN POWER OFF.** Do not leave tool until it comes to a complete stop.
23. **DO NOT OPERATE TOOL WHILE UNDER THE INFLUENCE** of drugs, alcohol or any medication.
24. **DO NOT WORK IN HASTE** or operate tool if you are mentally or physically fatigued.
25. **IF THERE IS SOMETHING YOU DON'T KNOW OR UNDERSTAND — DO NOT OPERATE TOOL!** Ask for help first. Find out from someone who does know.
26. **BAD HABITS ARE DANGEROUS.** Periodically review all safety procedures.

## IV. UNPACKING

Your machine and accessories have arrived in a thick cardboard shipping carton. If you find damage to the components after you've signed the delivery receipt and the truck and driver have gone, you will need to file a freight claim with the carrier. Save the containers and all packing material for inspection by the carrier or their agent. Without the packing material, filing a freight claim could be difficult. Of course, if you ever need advice in this matter, please call us.

**CAUTION:** The Model G1059 Table Saw is heavy and can be awkward to handle. **DO NOT** over-exert yourself when lifting it out of the carton; get assistance, if needed. In the event that this table saw must be moved up or down a flight of stairs, be sure that the stairs are capable of supporting the combined weight of people and the machine.

If you are completely satisfied with the condition of your shipment, you should then inventory its parts.

## V. PIECE INVENTORY

After all the parts have been removed from the container, you should have:

- Stand Components
- V-Belt
- Table Saw Unit
- Motor and Pulley
- Miter Gauge
- Extension Wings (2)
- Saw Guard
- Fence Rails (2)
- Fence Assembly
- Bolt Bag

If anything is missing, call or write to the appropriate regional service department listed in the Introduction. If anything is damaged, please follow the procedures described in the Unpacking section at the top of this page.

We have detailed on the following page the minimum quantity, size, and fastener location for your convenience.

QTY.	DESCRIPTION	LOCATION
16	Carriage Bolts $\frac{5}{16}$ " - 18 x $\frac{1}{2}$ "	Stand
16	Hex Nuts $\frac{5}{16}$ " - 18	Stand
16	Flat Washers $\frac{5}{16}$ "	Stand
16	Lock Washers $\frac{5}{16}$ "	Stand
4	Hex Bolts $\frac{5}{16}$ " - 18 x $\frac{5}{8}$ "	Cabinet
4	Hex Nuts $\frac{5}{16}$ " - 18	Cabinet
4	Flat Washers $\frac{5}{16}$ "	Cabinet
4	Lock Washers $\frac{5}{16}$ "	Cabinet
4	Hex Bolts $\frac{5}{16}$ " - 18 x $\frac{5}{8}$ "	Motor
4	Hex Nuts $\frac{5}{16}$ " - 18	Motor
8	Flat Washers $\frac{5}{16}$ "	Motor
8	Lock Washers $\frac{5}{16}$ "	Motor
1	Carriage Bolt $\frac{1}{4}$ " - 20 x $1\frac{3}{4}$ "	Guard Plate
1	Flat Washer $\frac{1}{4}$ "	Guard Plate
1	Wing Nut	Guard Plate
4	Fence Rail Bolts	Fence Rail
4	Fence Rail Spacers	Fence Rail
1	Hex Bolt $\frac{1}{2}$ " - 12 x $1\frac{5}{16}$ "	Guard Bracket
1	Lock Washer $\frac{1}{2}$ "	Guard Bracket
4	AGX Bolt $\frac{1}{4}$ " - 20 x $\frac{5}{8}$ "	Feet
4	Flat Washers $\frac{1}{4}$ "	Feet
4	Hex Nuts $\frac{1}{4}$ " - 20	Feet
6	Hex Bolts $\frac{3}{8}$ " - 16 x $\frac{3}{4}$ "	Wing
6	Lock Washers $\frac{3}{8}$ "	Wing

If everything is in order, set the parts aside until they're ready for assembly.

## VI. CLEANUP

All of the unpainted surfaces of your machine have been treated with a rust preventative to protect them from corrosion during shipment. The best way to remove this substance is with common paint thinner (mineral spirits) and plenty of clean rags. Don't use gasoline or other petroleum-based solvents because of their extremely low flash points. Don't use chlorinated solvents like perchloroethylene; they will lift the paint and ruin the finish. Before cleaning, please note the following safety rules when working with solvents:

- Read and follow all directions and warnings on the solvent label.
- Work only in a well ventilated area.
- Do not work near any open flame (e.g., pilot lights, kerosene heaters, and so on).
- **DO NOT** smoke while working with flammable materials.
- Rags from the cleaning process are quite combustible. Dispose of waste towels properly, so they don't create a fire hazard.

## VII. ELECTRICAL SERVICE REQUIREMENTS

Wiring instructions for both voltages are included as an insert with this manual. For your convenience, the G1059 is pre-wired for 110V operation.

### A. CIRCUIT LOADING

Your new Model G1059 Table Saw will operate on either 110/115 volts or 220/230 volts, single phase power. The 1½ HP motor will draw roughly 12 amps at 110/115 volts or 6 amps at 220/230. These loads are not excessive; however, if you operate this machine on any circuit that is already close to capacity, it might blow a fuse or trip a circuit breaker. If an unusual load does not exist, however, and power failure still occurs, consult a qualified electrician. Better yet, consider a dedicated circuit for your machine.

### B. GROUNDING

**This machine must be grounded.** This machine is equipped with a power cord with a ground wire. Please ensure that the machine is continuously grounded from the motor to the machine frame and then to a known ground. Verify that any existing outlet and circuit you intend to use is actually grounded. If it is not, it will be necessary to run a separate 12 AWG copper ground wire from the outlet to a known ground. If you're adding a new circuit, ensure that the circuit is grounded to the grounding terminal in your electrical service panel. Under no circumstances should the grounding pin from any three-pronged plug be removed.

### C. GENERAL INFORMATION

**Fusing** Fuse at 15 amps. Fuses rated higher will not adequately protect this motor. **Note:** Any equipment returned to Grizzly that shows evidence of being over-fused will be repaired or replaced at the customers expense, *regardless of the present warranty status.*

**Extension Cords** If used, extension cords must be rated Hard Service (grade S) or better. Conductor size must be 14 AWG (110/115V) or 12 AWG (220/230V) for cords up to 50 feet long. Your extension cord must also contain a ground wire and plug pin. Always repair or replace extension cords if they become damaged.

### D. 220 VOLT OPERATION

Although the motor supplied with this table saw is pre-wired for 110/120 volts, it can also be converted to operate at 220/240 volts. If you wish to convert this motor, follow the wiring diagram on the insert provided with this manual. You must also remove the 110/120 volt plug supplied, purchase a recommended 220/240 volt plug and power cord. Make sure that the plug matches the outlet you intend to use. Also ensure that the outlet and plug type selected are suitable for use as an equipment grounding method, since not all kinds are. We have detailed two 220/240 volt outlet/plug configurations that are the grounding type and safe to use. See Figure 1. The NEMA style numbers are given for your reference and are standard regardless of the brand purchased.

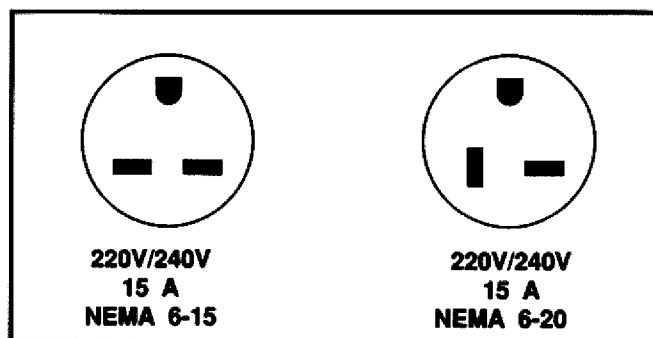

**Figure 1** Two typical 220V plug configurations

## **E. WORD OF CAUTION**

In this section we have covered some basic electrical requirements for the safe operation of your Model G1059 Table Saw. As with the safety rules in the preceding section, these requirements are not necessarily comprehensive. Further, you must be sure that your particular electrical configuration complies with state and local codes. The best way to ensure compliance is to check with your local municipality or licensed electrician.

## **VIII. ASSEMBLY**

The G1059 Table Saw has been largely pre-assembled at the factory. However, some components must be assembled or installed after delivery. We have organized the assembly process into steps. Please follow along in the order in which we have presented them here. We also recommend that you spend some time with the diagrams and parts lists to become familiar with all the parts before you begin. The G1059 should be assembled in this order:

Stand  
Mount Unit to Stand  
Hand Wheels  
Motor, Pulley and V-Belt  
Wiring  
Extension Wings  
Guide Rails and Fence  
Blade Installation  
Blade Guard and Splitter  
Table Insert

Before you assemble your table saw, please consider the following facts about sheet metal.

- Sheet metal sometimes has a tendency to “spring” after it is manufactured. Therefore, it may take a little extra muscle to get bolt holes to line up, or to slide assemblies into place. However, if it takes too much effort to get parts to fit, contact Grizzly for advice.
- All die-cut metal parts have a sharp burr edge (called “flashing”) on them after they are formed. This is removed at the factory. Sometimes, though, a bit of flashing might escape inspection. Please examine the edges of die-cut metal parts **before** handling them.

## A. TOOLS REQUIRED

Common hand tools are all that are necessary to assemble this machine. Specifically, you will need a 10mm and 12mm wrench, a set of metric Allen wrenches, screwdriver, Phillips screwdriver, and a 6" or 8" adjustable wrench.

## B. STAND

The G1059 Table Saw stand is an A-frame, panel type stand. The front and rear panels are connected by cross members near the stand's bottom. Refer to the stand assembly diagram and locate all the parts so they are within easy reach.

1. Attach the top panel to the front and rear panels with eight (8)  $\frac{5}{16}$ " - 18 x  $\frac{1}{2}$ " carriage bolts, washers and nuts provided.
2. Fasten the lower stand braces to the front and rear panels with eight (8)  $\frac{5}{16}$ " - 18 x  $\frac{1}{2}$ " carriage bolts, washers and nuts provided. Hand tighten for now.
3. Level the stand by checking the side of the stand for symmetry. Measure diagonally from top to bottom and adjust the stand so both diagonals are equal. Securely tighten all of the stand bolts.
4. Flip the stand upside down and attach the rubber feet with four (4) Phillips head screws, washers and nuts provided.
5. Now, flip the stand upright again and locate it near its final position.

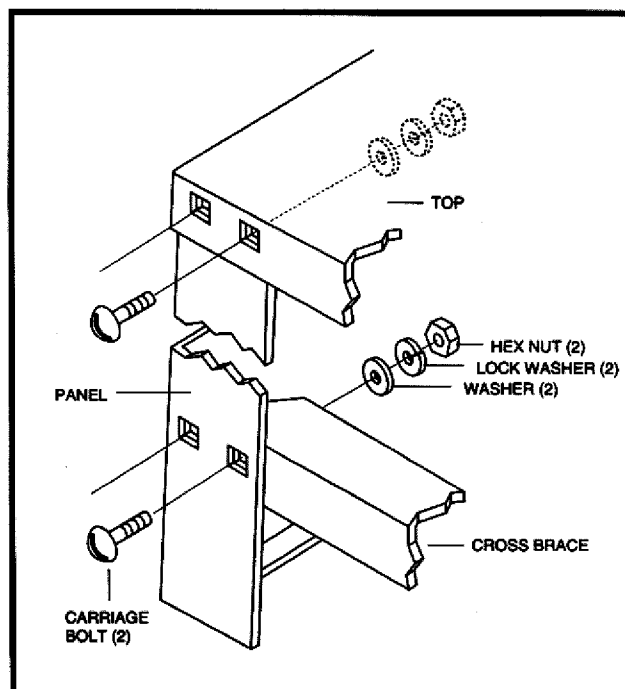
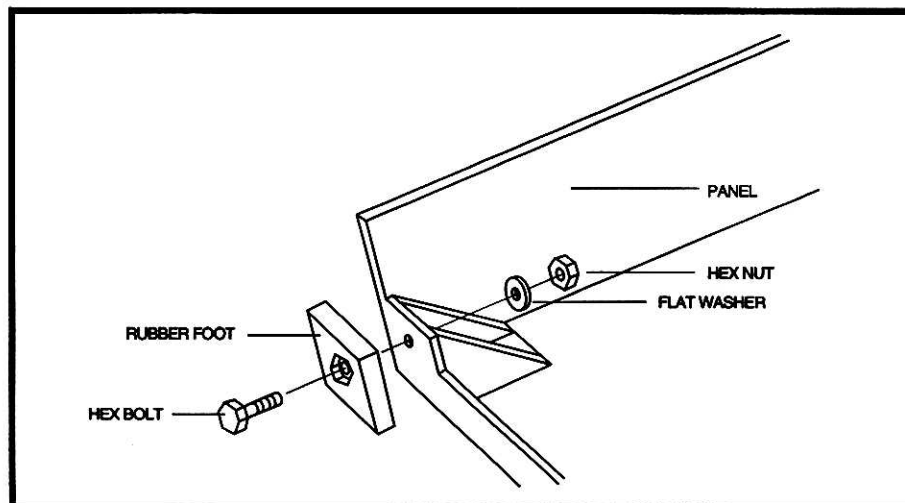
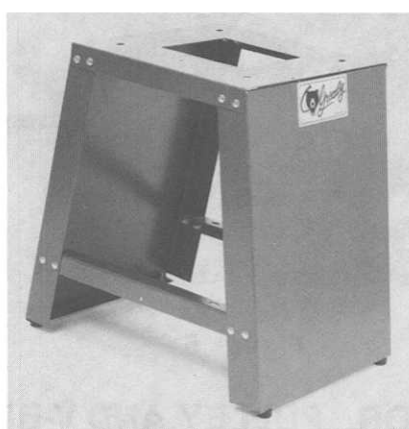

Figure 2



**Figure 3**



**Figure 4**

### **C. MOUNTING TABLE SAW UNIT TO STAND**

Place the table saw unit on the stand. It may be more convenient to turn the table saw unit upside down and then place the inverted stand on top of the table saw unit. After the stand has been secured to the table saw unit, the whole assembly can be tilted to the upright position.

**NOTE:** It may also be more convenient to check and make saw blade adjustments before mounting the table saw unit to the stand. Please refer to the Blade Installation Section and the Blade Adjustment Section if you prefer to check adjustments before mounting the table saw unit to the stand.

**CAUTION:** The table saw is heavy and awkward to handle. We strongly recommend that you get assistance when lifting. The table saw is also very unstable until it is permanently mounted to the stand. Ensure that it does not slide off of the stand.

Line up the mounting holes in the stand's top panel with the holes in the base of the table saw unit and secure with the four (4)  $\frac{5}{16}$ " - 18 x 1" hex head bolts, washers and nuts provided. Again, ensure that all stand fasteners and table saw mounting bolts are secured tightly.

## D. HAND WHEELS

The hand wheels control blade height and arbor tilt. To attach the hand wheels, proceed as follows:

1. Position the two hand wheels over the arbor tilting shaft on the side of the table saw and the blade raising shaft on the front. See Figure 5. Ensure that the slots in the hand wheels engage with the roll pins in the shafts.
2. Secure the two lock knobs over the ends of each shaft.



Figure 5

## E. MOTOR, PULLEY AND V-BELT

1. Position the  $\frac{1}{4}$ " x 20 x  $1\frac{3}{4}$ " carriage bolt on the pulley guard bracket, as shown in Figure 6.

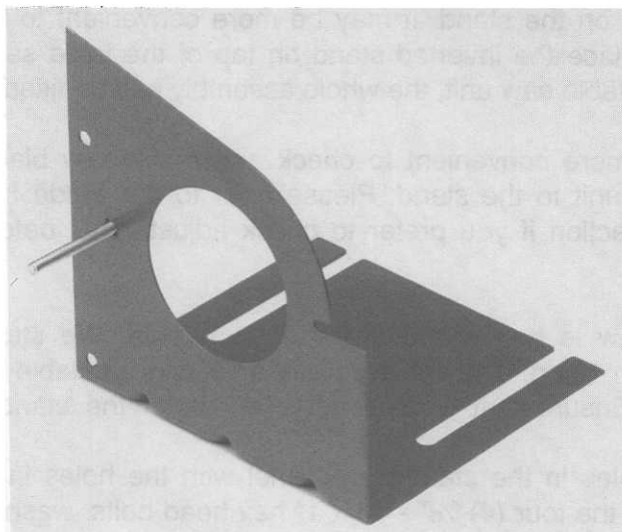

Figure 6



2. Place the motor upside down on the floor or bench.

**WARNING:** Motor should not be connected to any power source at this time.

3. Fasten the pulley guard bracket and motor plate to the motor using four (4)  $\frac{5}{16}$ " - 18 x  $\frac{5}{8}$ " hex head bolts, washers and nuts provided. See Figure 7. The edge of the motor plate and guard bracket should be roughly parallel to each other.

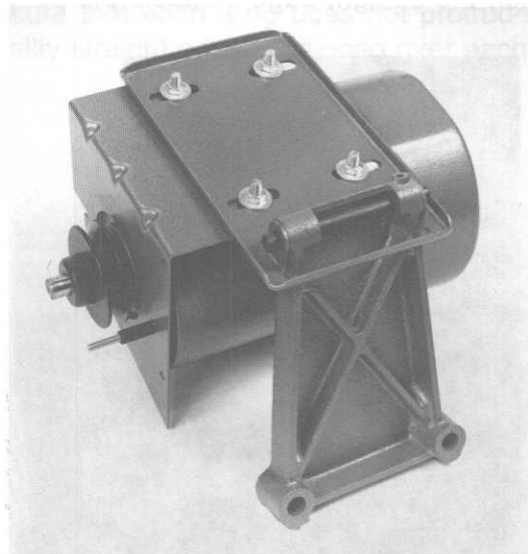
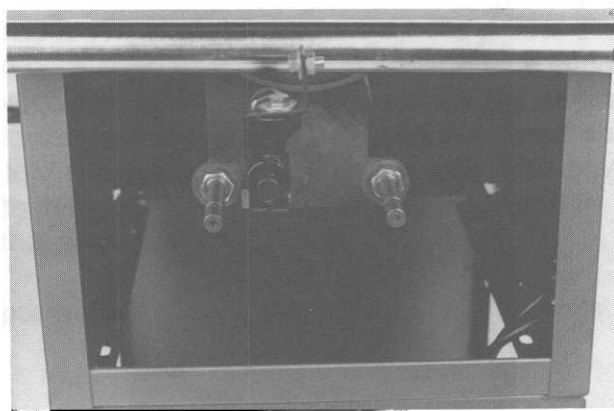

**Figure 7**

4. Mount the bracket to the motor plate by inserting the rod through the holes. Tighten the Allen setscrew, making sure that it seats into the groove in the rod.

5. Turn the motor assembly right side up and slide the bracket onto the two posts shown in Figure 8. Tighten the two hex bolts located on top of the mounting bracket.

**NOTE:** For ease of assembly, tilt the arbor to 0° by turning the arbor tilting hand wheel on the side of the saw.



**Figure 8**

In order to ensure proper power transmission from the motor to the saw arbor, pulleys should be properly aligned.

1. Slide the motor pulley onto the motor shaft, line up keyway, insert key and tighten the setscrew.
2. Align the two pulleys with a good quality straight edge as shown in Figure 9. The two pulleys are aligned when the straight edge contacts the pulley rims at four points.

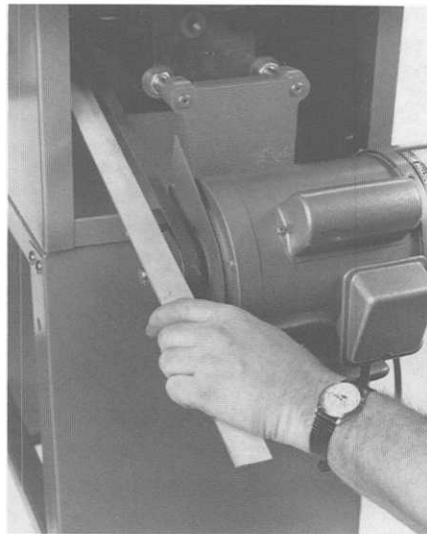

**Figure 9**

3. If necessary, loosen the motor bolts and slide the motor so the pulleys are in alignment. Re-tighten the motor bolts.
4. Ensure that the pulleys are secured to each shaft. Attach the V-Belt to the motor and arbor pulley by lifting up on the motor assembly. The weight of the motor will ensure proper V-Belt tension.
5. Attach the pulley cover and secure with the wing nut and washer, as shown in Figure 10.

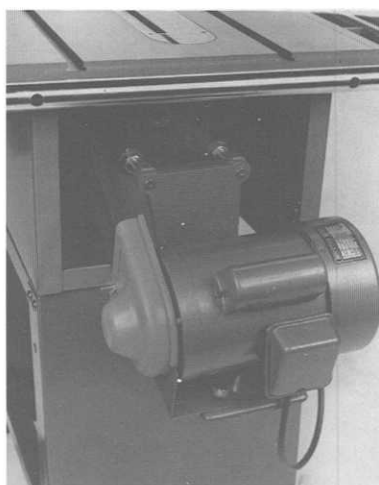

**Figure 10**

## F. EXTENSION WINGS

Inspect the extension wings for any burrs or foreign material that may restrict assembly. The surfaces that mate to the table must be smooth and flat. Use a wire brush or file if necessary to clean and smooth the edges. To attach the extension wings:

1. Secure each wing to the table using the three (3)  $\frac{3}{8}$ " - 16 x  $\frac{3}{4}$ " hex head bolts, and washers provided. Ensure that each wing does not protrude above the table surface. Check with a good quality straight edge positioned over each bolt location. See Figure 11 below.

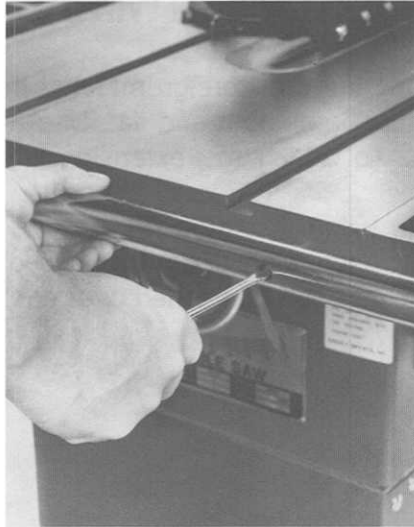

**Figure 11**

## G. GUIDE RAILS

At this point, attach the fence guide rails to the tablesaw.

1. The front and rear guide rails attach to the table with four (4) fence rail bolts and four (4) spacers provided. Four of the fence rail bolts screw directly into the tapped holes in the front and back edge of the table. Ensure that the curved spacers fit against the round rails between the rails and the table and wing edges. The calibrated rail should be located on the front of the saw and be positioned so the calibrations are visible to the operator. The guide rails can be adjusted for bevel cuts or maximum ripping capabilities by aligning the bolts on the guide rails with the alternate tapped holes provided on the saw table.
2. With the rails and spacers in position, tighten the slot head bolts securely. See Figure 12.
3. Slide the fence onto the rails. Fence adjustment will be covered in the Fence Adjustment Section of this manual.



**Figure 12**

## **H. BLADE INSTALLATION**

**IMPORTANT:** When installing or removing saw blades, moulding heads or dado heads from your table saw, always ensure that the power cord is unplugged. Blades and cutters are very sharp and should be handled with care.

The G1059 Table Saw will accept any circular saw blade in good condition, up to 10" in diameter with a standard  $\frac{5}{8}$ " diameter arbor bore. To install saw blade, proceed as follows:

1. Remove the table insert or throat plate from the table. Unscrew the nut from the arbor and remove the blade support collar.

**IMPORTANT:** The nut and arbor have reverse threads. Loosen the nut by turning it clockwise.

2. Slide the saw blade over the arbor, ensuring that the teeth are pointing in the direction of arbor rotation. The arbor must rotate in the clockwise direction when viewed from the end of the arbor. The top of the blade will rotate towards the front of the saw and the saw teeth must point towards the front of the saw.
3. Replace the blade support collar and nut, turning the nut counter clockwise. Use the wrench supplied with the saw to tighten the nut. The blade can be backed-up by placing a piece of scrap wood against the blade on the back side of the table. See Figure 13. Do not use excessive force when tightening the nut since over tightening will distort the saw blade and may cause excessive run-out. Return the throat plate to the table top.
4. To remove the blade, reverse the procedure in Step 3 above. When loosening the nut, turn clockwise and use a scrap piece of wood against the saw blade on the front side of the table.

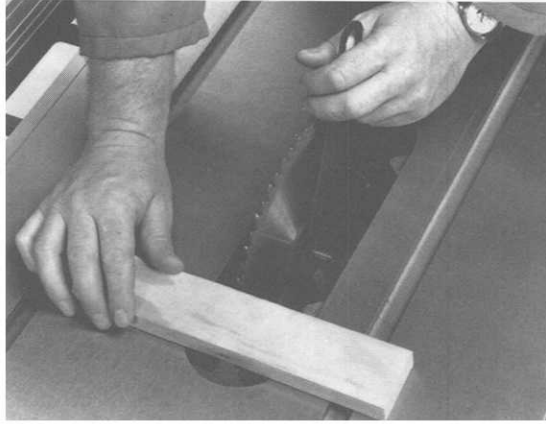

**Figure 13**

## **I. BLADE GUARD AND SPLITTER**

**IMPORTANT:** The blade guard must always be used during sawing operations.

1. Attach the guard mounting bracket to the rear saw trunnion with the  $\frac{1}{2}$ " -12 x 1" hex bolt provided. See Figure 14.
2. Attach the blade guard to the guard mounting bracket using two (2)  $\frac{5}{16}$ " -18 x  $\frac{5}{8}$ " hex head bolts provided and secure.
3. Use a straight edge to line up the guard with the saw blade. See Figure 15. Shim with flat washers on the side of the bracket for proper alignment. Fine adjustment can be checked by running a test piece through the saw and slightly bending the guard if needed.

**CAUTION:** Do not operate saw until all other adjustments have been made and you understand all operating and safety procedures.

4. Make sure that the guard plates move freely and are adjusted correctly.

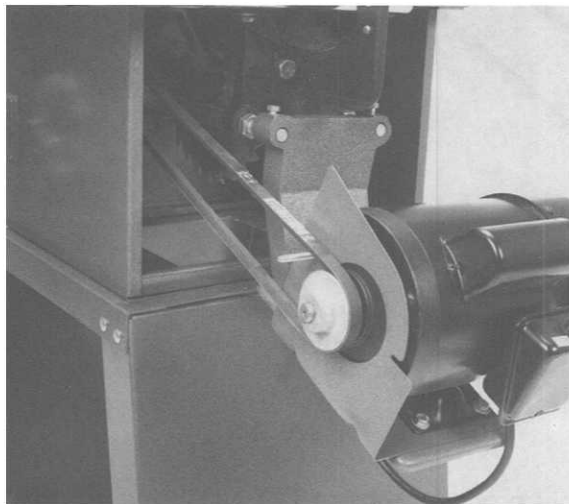

**Figure 14**

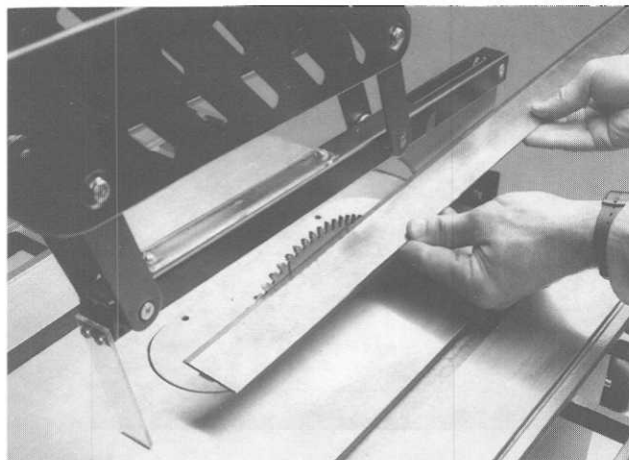

**Figure 15**

Inspect all work up to this point and ensure that all fasteners are tight.

## **J. TABLE INSERT**

The table insert or throat plate is positioned in the opening in the saw table. The insert should be level with the saw table surface. Two inserts are included with this saw; one for single blades and one for dado heads. To level the inserts:

1. Turn the four adjusting screws in the top of the insert until the insert is flush with the table surface. See Figure 16.
2. Check across the top of the insert with a straight edge to ensure that it is flush with the table top.

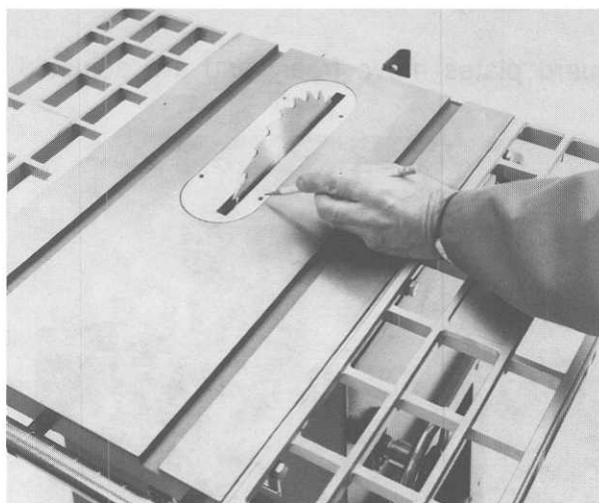

**Figure 16**

This concludes the assembly process. Please **DO NOT** operate this saw until you have read and have followed the Controls and Adjustments Section, Table Saw Safety Section and Operating Procedures Section.

## IX. CONTROLS AND ADJUSTMENTS

In this section we will describe how to adjust your table saw for optimum performance.

**WARNING:** Do not make adjustments while the table saw is running. Ensure that the switch is off, power is disconnected and moving parts have stopped before making adjustments.

### A. FENCE ASSEMBLY

The primary purpose of the fence is to support the material during ripping operations. Once the fence is set at the desired distance from the blade, multiple pieces can be ripped with uniform results.

**CAUTION:** Never cut material on the table saw without supporting the material with the fence during ripping operations or with the miter gauge during crosscutting.

The rip fence can be located on either side of the saw blade; however, the most common location is on the right side of the blade. To move the fence, turn the lock knobs counter-clockwise and push it to the desired distance from the blade.

We recommend facing the metal fence with a straight piece of wood. This will prevent thin stock from wedging between the fence and table surface. It will also make dado cutting and ripping narrow pieces safer since the blade or cutter head will be separated from the metal fence. To mount a wood auxiliary fence to the metal fence:

1. Cut a piece of wood approximately  $\frac{3}{4}$ " thick and as long and as wide as the rip fence.
2. Attach the auxiliary wood fence to the rip fence using three wood screws fastened through the holes provided in the rip fence. See Figure 17.

**Note:** Ensure that the wood facing piece fits close to the table surface along its full length so that thin stock cannot slide under the fence during cutting. Also keep in mind that adding an auxiliary fence will cause the scale on the fence rails to be miscalibrated by the amount of the thickness of the fence.

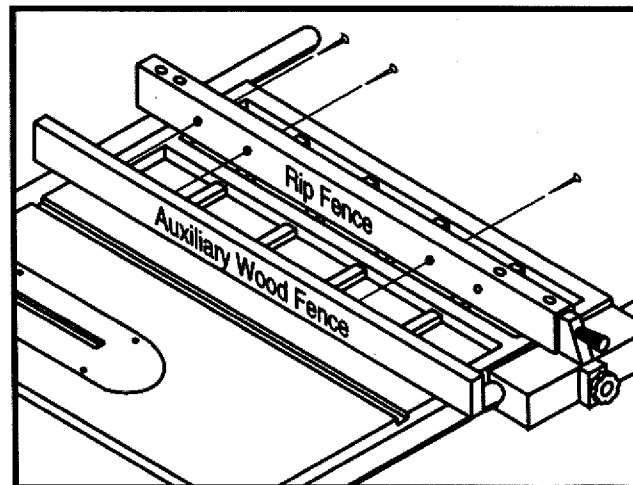

Figure 17

Proper fence alignment is essential for precise and safe cuts on the table saw. The rip fence must be adjusted so it is parallel to the saw blade when the large knob is locked.

On the front of the fence are two knobs. One locks the front of the fence; the other locks the rear.

To adjust the rip fence so it is parallel to the saw blade:

1. Position the fence assembly so the face of the rip fence is flush with the edge of one of the miter gauge slots. For proper alignment the fence must be flush with the miter gauge slot along its entire length after the front locking knob has been tightened.
2. If the fence is flush at one end but not the other, keep the fence in the locked position on the front rail and loosen the two bolts on top of the fence near the front of the saw.

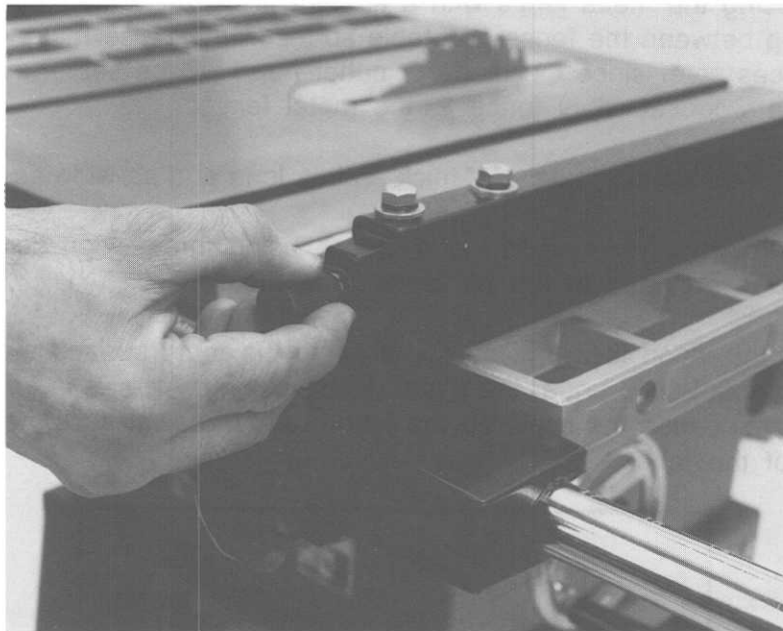

**Figure 18**

3. Push the back of the fence in the desired direction so the face of the fence is flush with the edge of the miter slot.
4. Tighten the two bolts on top of the fence near the front of the saw and ensure that the face is still flush with the miter slot.

If the fence is still not flush with the edge of the miter slot, repeat Steps 1 through 4 above.



## B. BLADE ADJUSTMENTS

For precise cuts and safe operation, the saw blade must be set parallel to the miter gauge slots. To check for parallelism between the blade and miter slot, use a machinist's rule or accurate ruler to measure the distance between the blade and the miter slot.

1. Raise the blade to its maximum height. Mark one tooth of the saw blade with a pencil and rotate the blade to the front of the saw table. Measure this distance between the blade and the miter slot and record.
2. Rotate the saw blade so the marked tooth is positioned at the rear of the saw table. Measure this distance and record.
3. If the two measurements are the same, then the blade is parallel to the miter slot. If the two measurements differ by more than  $\frac{1}{64}$ ", then the saw carriage assembly must be adjusted in the desired direction.

To adjust the saw carriage:

1. Just loosen three of the four bolts that hold the carriage assembly to the tabletop. Their locations are shown in Figure 20.

**NOTE:** if you are making adjustments prior to mounting the table saw unit to the stand, we recommend that you place the unit upside down on a work surface and clamp across the table trunnions with a bar clamp to hold the carriage assembly together.

2. Pivot the carriage assembly in the desired direction and re-tighten the three loosened bolts.
3. Re-check the measurements described in Steps 1 through 3 above and readjust the saw carriage assembly if necessary.

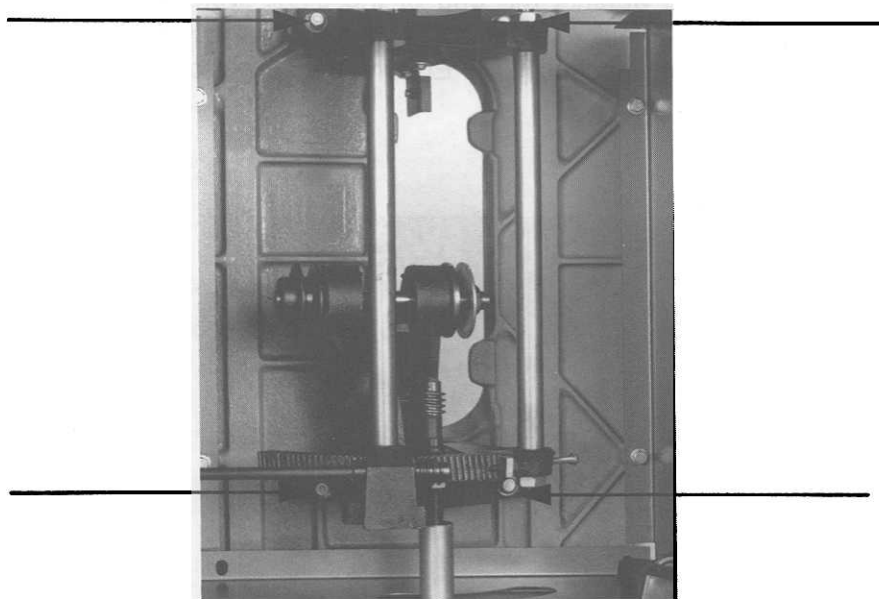

**Figure 20** (Saw is shown upside down.)

## C. 45° AND 90° POSITIVE STOPS

This saw is equipped with 45° and 90° positive stops. To set these stops, proceed as follows:

1. Raise the saw blade to its maximum height by turning the front hand wheel clockwise.
2. Set the blade at 90° to the table by turning the side hand wheel as far as it will go.

**CAUTION:** Do not force the blade when setting 45° or 90°. If you feel resistance, stop turning the hand wheel(s).

3. Place a machinist's square or adjustable square on the table surface as shown in Figure 21 and inspect for any variation between the blade and the square.

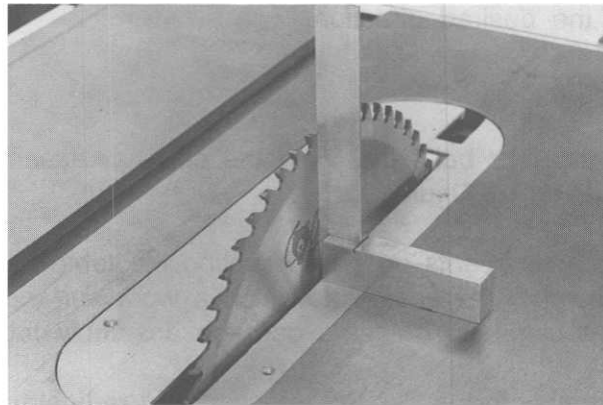

**Figure 21**

4. If there is any variation between the blade and the edge of the square, loosen locknut (A) as shown in Figure 22 and turn the adjusting stop screw (B) in or out. The adjusting stop screw (B) should stop against the end of the tilting worm gear when the blade is at 90° to the table. Re-check and re-adjust if necessary. Once you are satisfied with your adjustment, tighten locknut (A). Ensure that the stop screw does not turn when tightening the locknut.

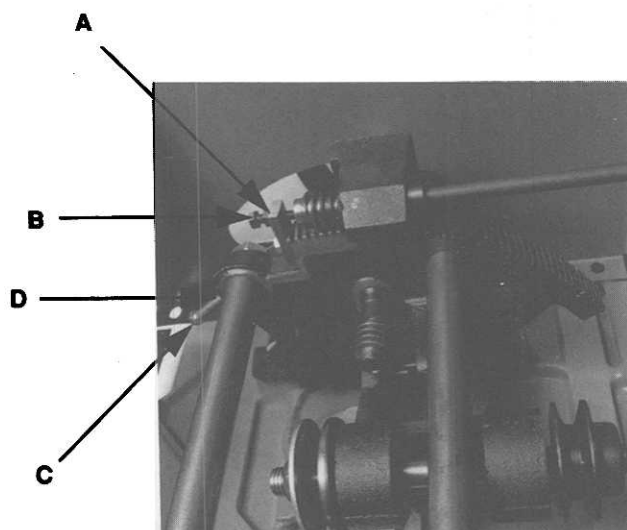

**Figure 22**

5. Now tilt the blade to 45° and inspect the angle with a combination square or bevel gauge set at 45°.
6. If the 45° positive stop is not set true, loosen locknut (D) and turn screw (C) in or out depending upon the direction desired. Re-check and re-adjust, if necessary. Tighten locknut (D).

## D. WORM GEAR MECHANISM

When turning the front hand wheel, the degree of difficulty can be adjusted to suit your particular preference or to compensate for wear. Adjustment is possible because the elevating shaft and the tilting shaft pass through a separate eccentric sleeve. This eccentric sleeve allows the worm gear to fully or partially contact the gear on which it meshes. To adjust the worm gear mechanism:

1. Loosen locknut (B) and remove from the eccentric sleeve. See Figure 23.
2. Loosen the bushing by unscrewing the setscrew (A). Slide the bushing off of the shaft.
3. Rotate the eccentric sleeve to the desired position and re-tighten the bushing and check nut (B). Check resistance and repeat if necessary.

## E. POINTER

To set the pointer to 0°, proceed as follows:

1. Ensure that saw blade is set at 90° to the table surface. See Section C above.
2. Loosen setscrew A in Figure 23 (below) with a metric Allen wrench, and move pointer to 0° on the graduated scale.
3. Re-tighten the Allen setscrew.

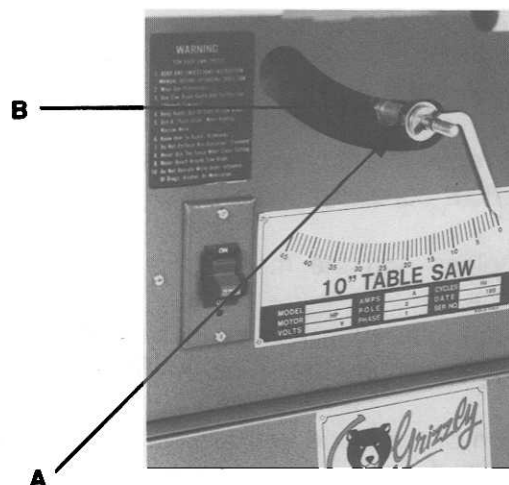

**Figure 23**

## F. MITER GAUGE

To adjust the miter gauge so it is perpendicular to the saw blade, proceed as follows:

1. Loosen the locking handle and place a square against the face of the miter gauge and miter slot.
2. Pivot the miter gauge so there is no variation between the gauge and square. Lock the handle by turning clockwise.
3. Follow Steps 1 and 2 to set the miter gauge at 45° left and right. Use a combination square or set a bevel gauge at 45° to make adjustments to the miter gauge.
4. If necessary, loosen the locknuts and adjust setscrews to allow for quick setting back to 90° or 45° left and right.

## G. HAND WHEELS

The hand wheels that control the height of the blade and the tilt of the arbor are held in position by two lock knobs. To operate the hand wheel(s), loosen the lock knob in the center of the hand wheel and turn the hand wheel. Re-tighten the lock knob. If either lock knob does not adequately lock the hand wheel in position, loosen the setscrew in the collar and slide the collar towards the cabinet. Re-secure the setscrew with an Allen wrench.

This concludes table saw adjustments. Do not operate your table saw until you have read and understand the Table Saw Safety Information and Operating Procedures Section that follow.

## X. TABLE SAW SAFETY

Earlier in this manual we covered general shop and machine safety rules. This section will address safety rules specific to your table saw.

1. Be sure to observe all electrical requirements such as fuse sizing, wire sizing, machine grounding and any other electrical consideration.
2. Ensure that all guards are in place and the machine is stable before use.
3. **Always** wear eye protection while operating this table saw. Also use a respirator to avoid breathing dust. All safety equipment must be ANSI approved.
4. **Always** be aware of the condition of the wood you are cutting. Pay particular attention to knots, splits, and other potentially dangerous areas.

5. **Never** attempt to operate the table saw with blades that are dull or damaged. They will burn the wood and cause it to bind.
6. Maintain table saw in proper working condition. Perform machine inspections and maintenance services promptly when called for. Always put adjustment tools away after use.
7. Before machine inspection, maintenance or changing accessories: Turn off switch, unplug power cord and wait for all moving parts to stop.
8. Set blade height just above the material being cut.
9. During blind cutting, always be aware of the blade position.
10. Keep hands away from the blade during table saw operation. Use push sticks if material cannot be fed safely with your hands. Be aware that if the push stick contacts the blade, there is a chance that the push stick will be deflected out of your hand.
11. Cuts should always be fully supported by the table or some type of support fixture. **NEVER MAKE FREE-HAND CUTS.**
12. Position yourself so you are not directly behind the workpiece during ripping operations in case of kick-back. Also ensure that no one is standing in the line of kick-back.
13. **Do not** back workpiece away from the blade while the saw is running. If you need to back the work out, turn the table saw off and wait for the blade to come to a complete stop.
14. The blade should reach full speed before beginning a cut.
15. When replacing blades, make sure teeth face down towards the front of the table. Always check the blade direction arrow on the blade when installing new blades.
16. Always feed stock evenly and smoothly.
17. Do not reach over the blade during the cutting operation.
18. Do not allow the material to bind or pinch the back side of the blade.
19. Ensure that there is sufficient infeed and outfeed clearance for the material being cut.
20. Always use the miter gauge when cross-cutting material.
21. Never cut material with the miter gauge while it is contacting the fence.
22. Never leave the table saw running unattended.

# XI. OPERATING PROCEDURES

The table saw is one of the most frequently used pieces of equipment in the workshop. Although this saw has the capability of performing a wide range of tasks, the intent of this portion of the manual is to demonstrate basic table saw operations.

Using the table saw for the right job not only makes the job easier on yourself, it also yields better results. A properly adjusted and tuned table saw is also safer to operate and is capable of performing many sawing functions with ease and accuracy.

Many factors contribute to table saw performance. For example, using the wrong kind of blade or a cheap blade usually results in a poor cut. Misuse of the saw or using incorrect sawing techniques can be unsafe and will also result in frustration and poor cuts. Replace blades as necessary and make adjustments periodically to keep the saw in top condition.

Before starting the machine ensure that all fasteners are secure, all adjustments have been made and all guards are in place.

## A. TEST RUN

Please review the safety rules if you are unsure about the risks associated with operating this machine.

Now, assuming that all adjustments have been checked and everything is secure, you are ready to test the machine. Turn on the power supply at the main panel if not already on. Press the start button and have your finger on the stop button just in case. The table saw should run smoothly and free of vibration or rubbing noises. Unusual or strange sounds or symptoms must be investigated and the problem corrected before proceeding further.

**WARNING:** Make sure the G1059 is unplugged and all moving parts have come to a complete stop before investigating any problems or performing any maintenance or adjustments.

If everything is running smoothly, try cutting some wood. If something is not right, stop immediately, review your set-up and adjustments and remedy the problem before resuming operation.

## B. RIPPING

Ripping is the operation of making a lengthwise cut through a board as shown in Figure 24. The rip fence is used to position and guide the work. One edge of the work rides against the rip fence while the flat side of the board rests against the table. Since the fence supports the work, the workpiece must have a straight edge. The material must also lay flat on the table surface.

During any cutting operation, the saw guard must be used. The guard has a splitter to prevent the saw kerf from closing and pinching the blade. When ripping small stock, use a push stick. Do not cut material that is so small it can not be adequately supported by the table or fence.

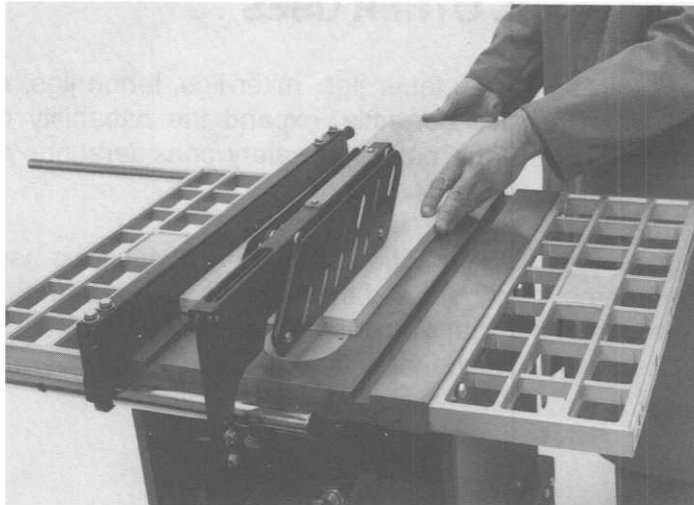

**Figure 24**

### **C. CROSSCUTTING**

Crosscutting requires the use of the miter gauge to position and guide the work. Place the workpiece against the miter gauge and slide the miter gauge and workpiece toward the saw blade as shown in Figure 25. The miter gauge may be used in either miter slot; however, the left-hand slot is preferred for most work. When bevel cutting, use the miter slot that does not cause the miter gauge to interfere with the blade or blade guard.

When crosscutting, hold the work firmly against the miter gauge and ease the work into the blade. When the piece has been cut off, pull back on the workpiece and miter gauge as a single unit. Never hold onto the opposite end of the workpiece since the piece may bind against the saw blade and cause it to kick back. Always move the fence out of the way when crosscutting to avoid binding and possible kick back of the workpiece.

For greater support, the miter gauge can be fitted with an auxiliary wood facing that should be at least  $\frac{3}{4}$ " thick. The wood facing can be secured with wood screws through openings provided in the miter gauge.

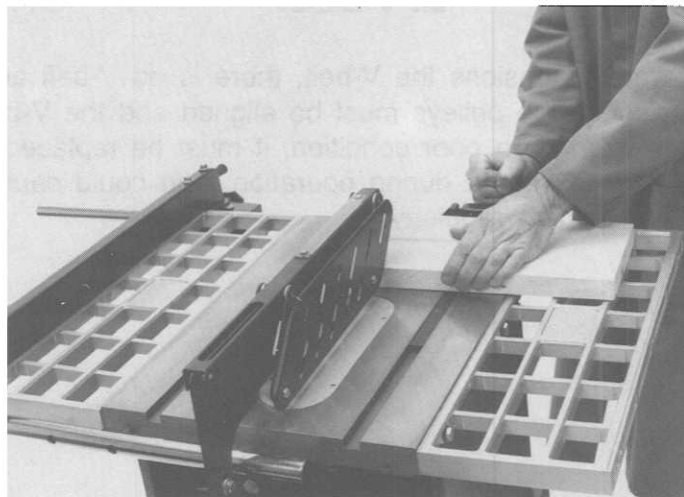

**Figure 25**

## **D. OTHER USES**

There are numerous accessories such as taper jigs, miter jigs, tenon jigs, and special cutters for table saw use which, when applied correctly, expand the capability of this machine. It is very important that you understand the particular safety considerations as each accessory relates to the table saw.

This sums up our thoughts on table saw operation. We cannot, within the pages of this manual, demonstrate all of the procedures, methods, and tricks necessary to be an accomplished table saw operator. We highly recommend that you refer to additional information regarding table saw use and operation. If you are inexperienced with using a table saw, start out simple.

## **XII. MAINTENANCE**

In this section, we will review a few simple items relating to proper maintenance of this table saw to ensure long life and low overall cost of operation.

### **A. LUBRICATION**

Shielded and pre-lubricated ball bearings require no lubrication on your part for the life of the bearings. In a continuous use environment, expect the bearings to last several years. With intermittent use, bearings can be expected to last much longer, depending on frequency of operation. All bearings are standard sizes and can be easily replaced.

As for other items on this machine (adjustment controls, for example), an occasional application of light oil is just about all that is necessary. Before applying, however, wipe off any grime or sawdust with a clean cloth or towel. Ensure that oil does not get on the pulleys or V-belt.

### **B. V-BELT**

Since the weight of the motor tensions the V-belt, there is no V-belt adjustment. However, for proper power transmission, the pulleys must be aligned and the V-belt must be in good condition. If the V-belt is worn or in poor condition, it must be replaced. Worn or damaged V-belts may cause the saw to vibrate during operation, and could cause damage or injury in the event of breakage. Inspect regularly.



## **C. TABLE MAINTENANCE**

The cast iron table on your Model G1059 Table Saw requires occasional attention to prevent damage from the elements; such as rust and corrosion. Grizzly recommends Top-Cote® table and tool surface sealant. An application of Top-Cote® creates a protective surface film on the saw table, which reduces workpiece friction and inhibits rust. Check your current Grizzly catalog for price and availability.

## **D. MISCELLANEOUS**

Always be aware of the condition of the table saw before using it. Routinely check the condition of the following items and repair or replace as necessary.

1. Loose mounting bolts.
2. Worn switch.
3. Worn or damaged power cord and/or plug.
4. Worn or damaged blade.
5. Worn or damaged V-belt.
6. Poor fence adjustment.
7. Poor blade adjustment.
8. Any other condition that may affect safe operation of this machine.

## **XIII. CLOSURE**

The following pages contain general specifications, a parts diagram, a parts directory and warranty and return information for your Model G1059 Table Saw.

You are welcome and encouraged to write or call the appropriate regional service department if you need parts or service assistance. Our service staff will be glad to help you. If you wish to comment on this manual, please write to our Bellingham, Washington location.

Again, thank you for your purchase. We sincerely appreciate your business and hope we have the opportunity to serve you again soon.

# XIV. MACHINE DATA

## GRIZZLY MODEL G1059 TABLE SAW

Design Type ..... 10" Tilting Arbor  
Maximum Diameter of Saw blade (Not Included) ..... 10"  
Diameter of Arbor ..... 5/8"

### Capacities:

Maximum Depth of Cut at 90° ..... 3 1/8"  
Maximum Depth of Cut at 45° ..... 2 1/8"  
Maximum Rip to Right of Blade (Standard) ..... 25"  
Distance Front of Table to Center of Blade ..... 15 1/2"  
Table in Front of Table at Maximum Cut ..... 11"  
Maximum Width of Dado ..... 3/4"

### Overall Dimensions:

With Wings and Guide Bars ..... 44 1/2"W x 26" D  
Weight (Shipping) ..... 255 lbs.  
Weight (in place) ..... 175 lbs.

Base Construction ..... Steel Assembly

### Table:

Height ..... 35 5/8"  
Size ..... 23" deep x 15" wide  
Size with Extension Wings ..... 23" deep x 30" wide  
Miter Gauge Groove Type ..... "T" slots in table  
Top ..... Precision Ground Cast Iron  
Wings ..... Precision Ground Cast Aluminum  
Miter Gauge ..... Die Cast Metal/Steel Bar  
Trunnions ..... Cast Iron

Fence Type ..... Front and Rear Locking

Guard Type ..... Steel

### Motor

Horsepower ..... 1 1/2 HP  
Phase Type/Voltage ..... Single Phase/110V/220V  
Hertz and RPM ..... 60 Hertz/3450 RPM  
Switch ..... Safety Toggle  
Power Transfer ..... Belt Drive  
Bearings ..... Shielded & Lubricated for Life Ball Bearings

*Specifications, while deemed accurate, are not guaranteed.*

## XV. PARTS LIST—BODY, TABLE & FENCE

Ref. No.	Part No.	Description
1	P1059001	Table Insert
1A	P1059001A	Dado Insert
2	P1059002	Bumper
3	PSS11	Setscrew 1/4" - 20 x 1/4"
4	P1059004	Table
5	P1059005	Cabinet
6	PW07	Flat Washer 5/16"
7	PB32	Hex Bolt 5/16" - 18 x 5/8"
8	P1059008	Tilt Scale
10	P1059010	Extension Wing
11	PLW04	Lock Washer 3/8"
12	PB21	Hex Bolt 3/8" - 16 x 3/4"
13	P1022014	Gear Bracket
14	P1059014	S.H. Screw 5/16" - 18
15	PW07	Flat Washer 5/16"
16	PN02	Hex Nut 5/16" - 18
17	P1059017	Front Guide Rail
18	P1059018	Special Bolt
19	P1059019	Fence Rail Spacer
20	P1059020	Rear Guide Rail
20A	P1059020A	Fence Rail Plug
21	P1059021	Width Regulator
22	P1059022	Hand Knob
24	P1059024	Clamp Block
25	PS06	P.H. Screw #10-24x3/8"
26	P1022037	Width Pointer
27	P1059027	Handle Knob
29	P1059029	Fence
30	PB09	Hex Bolt 5/16" - 18 x 1/2"
31	PW07	Flat Washer 5/16"
32	PB09	Hex Bolt 5/16" - 18 x 1/2"
33	PW07	Flat Washer 5/16"
34	P1059034	Clamp Rod
35	P1059035	Rear Clamp Block
36	P1059036	Roll Pin

Ref. No.	Part No.	Description
37	P1022060	Clamp Hook
38	P1022059	Spring
39	P1022061	Lever
40	P1059040	Left Guard
40A	P1059040A	Right Guard
41	P1059041	Raising Arm
42	PFH03	F.H. Screw 1/4"-20x1/2"
43	PW06	Flat Washer 1/4"
44	PLN02	Lock Nut 1/4" - 20
45	PRP26M	Roll Pin 5 x 26mm
47	P1059047	Supporting Arm
48	PRP10M	Roll Pin 5 x 36mm
49	P1059049	Spacer
50	PFH05	F.H. Screw 1/4"-20x3/4"
52	PLN02	Lock Nut 1/4" - 20
57	P1059057	Splitter
58	P1059058	See-Through Plate
60	PS18	P.H. Screw #10-24x1/4"
61	P1059061	Bracket
62	PB32	Hex Bolt 5/16" - 18 x 5/8"
62A	PN02	Hex Nut 5/16" - 18
63	PW07	Flat Washer 5/16"
64	PB53	Hex Bolt 1/2" - 12 x 1"
65	PLW07	Lock Washer
67	P1059067	Hand Knob
68	PN14	Hex Nut #8 - 32
69	PS25	P.H. Screw #8-32x1/4"
70	P1059070	Miter Gauge Body
72	P1059072	Miter Gauge Bar
73	P1059073	Locating Plate
76	P1059076	Pointer
77	PSS11	Setscrew 1/4" - 20 x 1/4"
78	PRP14M	Roll Pin 3 x 6mm
79	P1059079	Switch
79A	PS10	P.H. Screw #10-24x1/2"
79B	PN07	Hex Nut #10 - 24

# XVI. PARTS DIAGRAM—BODY, TABLE & FENCE

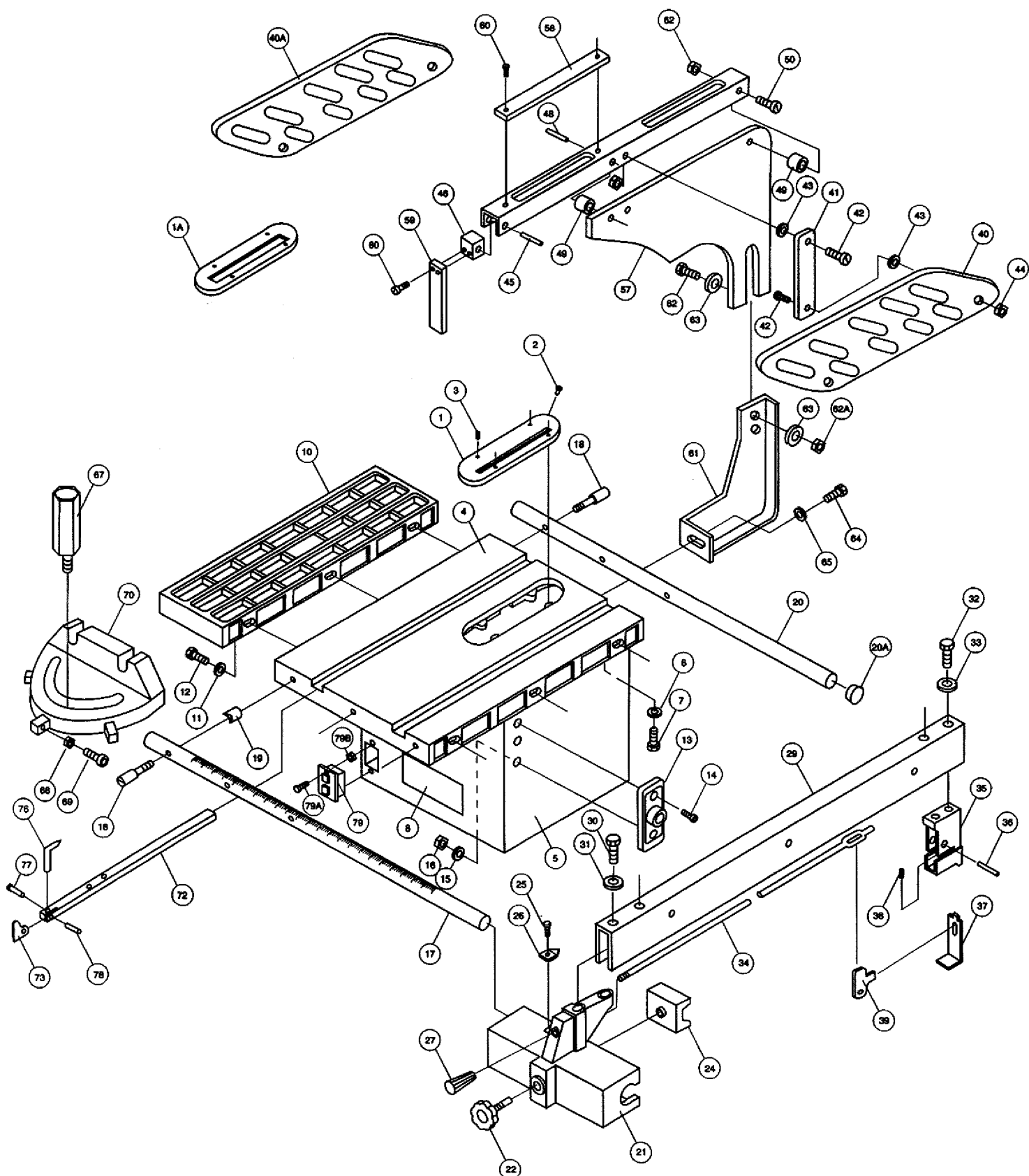

## XVII. PARTS LIST—INTERNAL

Ref. No.	Part No.	Description
80	P1059080	Knob
81	P1059081	Hand Wheel
81A	P1026101	Handle
81B	PN08	Hex Nut $\frac{3}{8}$ " - 16
82	PW02	Flat Washer $\frac{3}{8}$ "
83	P1059083	Pointer
84	PSS11	Setscrew $\frac{1}{4}$ "-20x $\frac{1}{4}$ "
85	P1059085	Set Collar $\frac{3}{8}$ "
87	P1059087	Tilt Shaft
87A	P1059087A	Eccentric Shaft
87B	PN16	Hex Nut $\frac{5}{16}$ " - 18
88	PRP17M	Roll Pin 3.5 x 24mm
89	PW02	Flat Washer $\frac{3}{8}$ "
90	P1059090	Rear Bracket
91	PB12	Hex Bolt $\frac{5}{16}$ " - 18 x $1\frac{1}{4}$ "
92	PW07	Flat Washer $\frac{5}{16}$ "
92A	PLW01	Lock Washer $\frac{5}{16}$ "
93	P1023040	Jam Nut
94	P1059094	Stop Block
95	PB31	Hex Bolt $\frac{1}{4}$ " - 20 x 1"
96	PW06	Flat Washer $\frac{1}{4}$ "
97	PSS12	Setscrew $\frac{1}{4}$ " - 20 x 1"
98	PN05	Hex Nut $\frac{1}{4}$ " - 20
99	P1059099	Front Trunnion
100	PRP26M	Roll Pin 5 x 26mm
101	PB32	Hex Bolt $\frac{5}{16}$ " - 18 x $\frac{5}{8}$ "
102	P1022102	Wavy Washer
103	P1059103	Eccentric Bushing
104	P1059104	Elevating Rod
105	PPR17M	Roll Pin 3.5 x 24mm
106	P1059106	Fiber Washer
107	P1059107	Spacer
108	P1059108	Arbor Bracket Shaft
109	P1022115	Arbor Nut
110	P1022116	Clamp Hook

Ref. No.	Part No.	Description
111	—	Blade (See Catalog)
112	P1059112	Arbor Bracket
113	PRP06M	Roll Pin 5 x 24mm
114	P1059114	Blade Arbor
116	P6203	Ball Bearing
118	PK23M	Key 5 x 5 x 25mm
119	P1059119	Wavy Washer
120	PR24M	Int. Retaining Ring 24mm
121	P1059121	Special Nut
122	P1059122	Arbor Pulley
123	PSS17M	Setscrew M8-1.25x6mm
124	P1059124	Rear Trunnion
125	P1059125	Rear Trunnion Bracket
127	PB12	Hex Bolt $\frac{5}{16}$ " - 18 x $1\frac{1}{4}$ "
128	P1059128	Motor Bracket
130	P1022131	Motor Plate Rod
131	P1059131	Motor Plate
134	PLW01	Lock Washer $\frac{5}{16}$ "
135	PN02	Hex Nut $\frac{5}{16}$ " - 18
136	P1022125-1	Motor Pulley
137	PSS01M	Setscrew M6-1x10mm
138	PVA40	V-Belt
139	PK22M	Key 5 x 5 x 24mm
140	G2535	Motor $1\frac{1}{2}$ HP
141	P1059041	Power Cord
142	P1059142	Switch Cord
146	PCB04	Cge. Bolt $\frac{1}{4}$ " - 20 x $1\frac{3}{4}$ "
148	P1059148	Guard Plate
151	P1059151	Guard Cover
154	PWN02	Wing Nut $\frac{1}{4}$ " - 20
156	P1059156	Tie Rod
157	PN08	Hex Nut $\frac{3}{8}$ " - 16
158	P1059158	Special Bolt
159	P1022148	Hex Spanner Wrench
162	PAW03M	Allen Wrench 3mm

# XVIII. PARTS DIAGRAM—INTERNAL

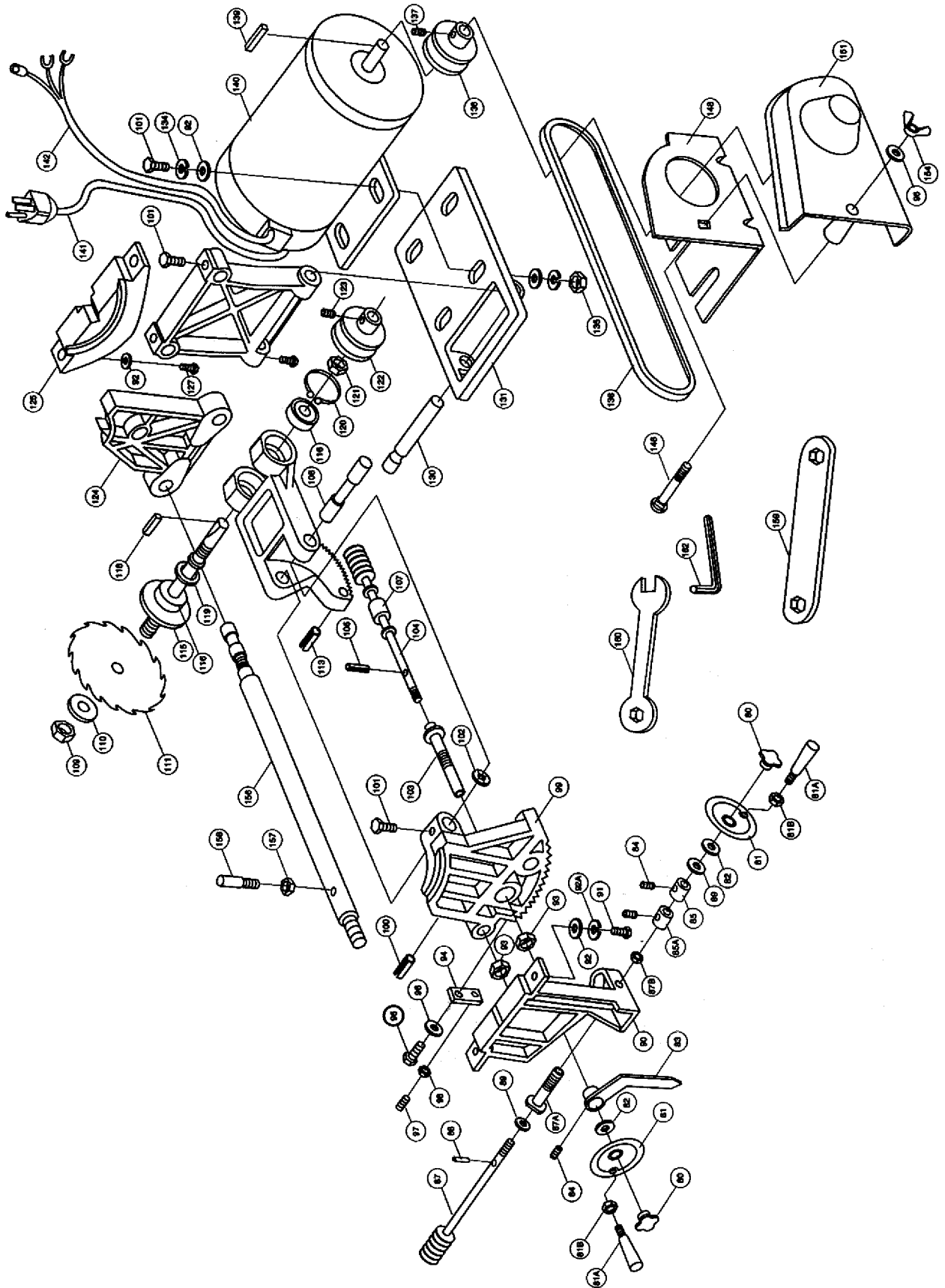

# XIX. STAND PARTS LIST & DIAGRAM

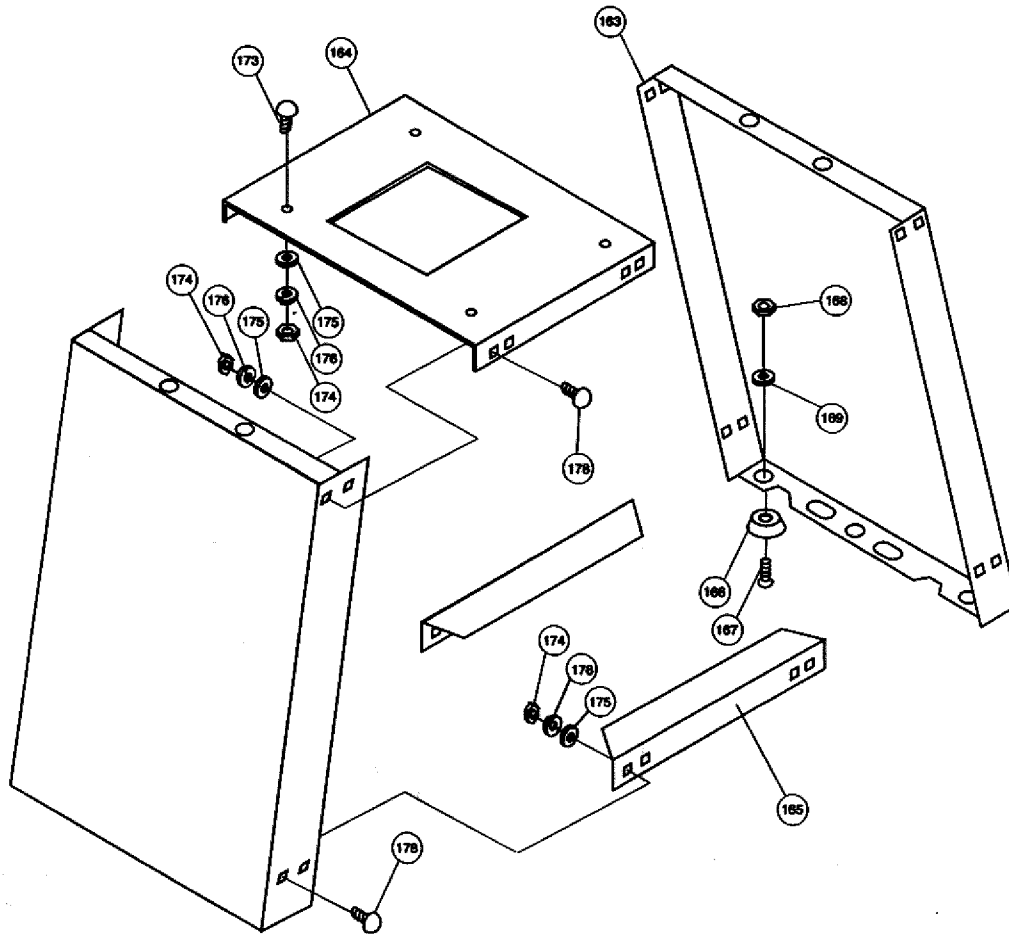

Ref. No.	Part No.	Description
163	P1059163	Stand Panel
164	P1059164	Top Panel
165	P1059165	Lower Brace
166	P1059166	Rubber Foot
167	PB02	Hex Bolt $\frac{1}{4}$ " - 20x $\frac{5}{8}$ "
168	PN05	Hex Nut $\frac{1}{4}$ " - 20
169	PW06	Flat Washer $\frac{1}{4}$ "

Ref. No.	Part No.	Description
173	PB32	Hex Bolt $\frac{5}{16}$ " - 18 x $\frac{5}{8}$ "
174	PN02	Hex Nut $\frac{5}{16}$ " - 18
175	PW07	Flat Washer $\frac{5}{16}$ "
176	PLW01	Lock Washer $\frac{5}{16}$ "
178	PCB02	Cge. Bolt $\frac{5}{16}$ " - 18 x $\frac{1}{2}$ "

## XX. TROUBLESHOOTING

SYMPTOM	POSSIBLE CAUSE	REMEDY
Motor will not start.	<ol style="list-style-type: none"> <li>1. Low voltage.</li> <li>2. Open circuit in motor or loose connections.</li> <li>3. Tool un-plugged.</li> </ol>	<ol style="list-style-type: none"> <li>1. Check power line for proper voltage.</li> <li>2. Inspect all lead connections on motor for loose or open connections.</li> <li>3. Check connection at outlet.</li> </ol>
Motor will not start; fuses or circuit breakers blow.	<ol style="list-style-type: none"> <li>1. Short circuit in line cord or plug.</li> <li>2. Short circuit in motor or loose connections.</li> <li>3. Incorrect fusing or circuit breakers in power line.</li> </ol>	<ol style="list-style-type: none"> <li>1. Inspect cord or plug for damaged insulation and shorted wires.</li> <li>2. Inspect all connections on motor for loose or shorted terminals or worn insulation.</li> <li>3. Install correct fuses or circuit breaker.</li> </ol>
Motor fails to develop full power (power output of motor decreases rapidly with decrease in voltage at motor terminals).	<ol style="list-style-type: none"> <li>1. Power line overloaded with lights, appliances and other motors.</li> <li>2. Undersize wires or circuits too long.</li> <li>3. General overloading of power company facilities.</li> </ol>	<ol style="list-style-type: none"> <li>1. Reduce the load on the power line.</li> <li>2. Increase wire size or reduce circuit length. Check extension cord (if applicable) for proper amperage.</li> <li>3. Call power company for power check.</li> </ol>
Motor overheats.	<ol style="list-style-type: none"> <li>1. Motor overloaded.</li> <li>2. Air circulation through motor restricted.</li> </ol>	<ol style="list-style-type: none"> <li>1. Reduce load on motor.</li> <li>2. Clean out motor to provide normal air circulation.</li> </ol>
Motor stalls (resulting in blown fuses or tripped circuit).	<ol style="list-style-type: none"> <li>1. Short circuit in motor or loose connections.</li> <li>2. Low voltage.</li> <li>3. Motor overload.</li> <li>4. Incorrect fuses or circuit breaker in power line.</li> </ol>	<ol style="list-style-type: none"> <li>1. Inspect connections on motor for loose or shorted terminals or worn insulation.</li> <li>2. Correct the low voltage conditions.</li> <li>3. Install correct fuses or circuit breakers.</li> <li>4. Reduce load on motor.</li> </ol>
Machine slows down when operating.	<ol style="list-style-type: none"> <li>1. Low voltage to motor.</li> <li>2. Applying too much pressure to workpiece.</li> </ol>	<ol style="list-style-type: none"> <li>1. Correct the low voltage conditions.</li> <li>2. Feed workpiece slower. Check blade sharpness.</li> </ol>
Saw vibrates excessively while running.	<ol style="list-style-type: none"> <li>1. Drive pulleys out of alignment.</li> <li>2. Saw on un-even surface.</li> <li>3. Saw blade bent or mis-aligned.</li> <li>4. Loose fastener in drive or trunnion assembly.</li> </ol>	<ol style="list-style-type: none"> <li>1. Check belt and pulleys for alignment.</li> <li>2. Check footing of table saw legs.</li> <li>3. Check for mis-alignment or damaged saw blade.</li> <li>4. Inspect saw for loose or missing fasteners.</li> </ol>
Workpiece unreasonably slow to cut. Wood smokes and finished cut is burnt.	<ol style="list-style-type: none"> <li>1. Saw blade dull, damaged, or incorrect for cutting task.</li> <li>2. Fence not parallel to saw blade.</li> </ol>	<ol style="list-style-type: none"> <li>1. Sharpen or replace saw blade. Verify blade requirements for cutting task.</li> <li>2. Check fence for alignment, using method described on pages 17-18.</li> </ol>
Workpiece binds while rip-cutting.	<ol style="list-style-type: none"> <li>1. Fence not parallel to sawblade.</li> <li>2. Workpiece bowed or twisted.</li> <li>3. Saw blade dull or damaged.</li> <li>4. Saw guard bracket poorly alligned.</li> </ol>	<ol style="list-style-type: none"> <li>1. Check fence for alignment, using method described on pages 17-18.</li> <li>2. Check wood for imperfections and correct.</li> <li>3. Inspect sawblade. Repair or replace, if necessary.</li> <li>4. Check saw guard for alignment – parallel to saw blade.</li> </ol>
Workpiece binds or kicks while cross-cutting.	<ol style="list-style-type: none"> <li>1. Workpiece touching fence.</li> <li>2. Improper grip at miter gauge.</li> </ol>	<ol style="list-style-type: none"> <li>1. Remove fence from cutting area.</li> <li>2. Improve grip on workpiece. Use clamp.</li> </ol>
Saw removes excessive stock.	<ol style="list-style-type: none"> <li>1. Damaged saw blade.</li> <li>2. Improper blade for task.</li> </ol>	<ol style="list-style-type: none"> <li>1. Inspect sawblade. Repair or replace, if necessary.</li> <li>2. Verify blade requirements for cutting task.</li> </ol>
Arbor height and tilt controls stiff – difficult to set.	<ol style="list-style-type: none"> <li>1. Adjustment shafts gummed up with sawdust and grime.</li> <li>2. Worm gear needs adjustment.</li> </ol>	<ol style="list-style-type: none"> <li>1. Clear worm gear of foreign substances, lubricate.</li> <li>2. Adjust worm gear. See page 21.</li> </ol>



# Parts and Service Information

Grizzly stands behind its products with a full parts inventory. These parts are available for purchase by Grizzly machine owners regardless of whether you are the original owner or a subsequent owner. If you are the original owner, please fill out the warranty information on the warranty card, remove the card from this manual and send it back to us within 10 days of product delivery. We appreciate any comments or suggestions and use them to better our products and service.

If you are not the original owner, please fill out one of the cards below, remove the card from the manual and send it back to us. By registering with us, you will have the same access to parts and service as the original owner.

If you need service or help with this machine, please call or write to us at the appropriate regional service location listed on page 1 of this manual.

## CHANGE OF OWNERSHIP

### Original Owner

Machine name & model no. \_\_\_\_\_

Name \_\_\_\_\_ Phone Number \_\_\_\_\_

Street \_\_\_\_\_

City \_\_\_\_\_

State \_\_\_\_\_ ZIP \_\_\_\_\_ Date purchased \_\_\_\_\_

### New Owner

Name \_\_\_\_\_ Phone Number \_\_\_\_\_

Street \_\_\_\_\_

City \_\_\_\_\_

State \_\_\_\_\_ ZIP \_\_\_\_\_ Date purchased \_\_\_\_\_

## CHANGE OF OWNERSHIP

### Original Owner

Machine name & model no. \_\_\_\_\_

Name \_\_\_\_\_ Phone Number \_\_\_\_\_

Street \_\_\_\_\_

City \_\_\_\_\_

State \_\_\_\_\_ ZIP \_\_\_\_\_ Date purchased \_\_\_\_\_

### New Owner

Name \_\_\_\_\_ Phone Number \_\_\_\_\_

Street \_\_\_\_\_

City \_\_\_\_\_

State \_\_\_\_\_ ZIP \_\_\_\_\_ Date purchased \_\_\_\_\_

From:

---

---

---

PLACE  
STAMP  
HERE



GRIZZLY IMPORTS INC

P O BOX 2069

BELLINGHAM WA 98227-2069

From:

---

---

---

PLACE  
STAMP  
HERE



GRIZZLY IMPORTS INC

P O BOX 2069

BELLINGHAM WA 98227-2069

# WARRANTY CARD

NAME \_\_\_\_\_ PHONE NUMBER \_\_\_\_\_

STREET \_\_\_\_\_

CITY \_\_\_\_\_ STATE \_\_\_\_\_ ZIP \_\_\_\_\_

MODEL # \_\_\_\_\_ PURCHASED FROM GRIZZLY, BELLINGHAM, WA   
OR WILLIAMSPORT, PA

INVOICE # \_\_\_\_\_

The following information is given on a voluntary basis. This information will be used for marketing purposes to help Grizzly develop better products. Your name will be included in our mailing list only. It will not be sold to other companies. Of course, all information is strictly confidential.

1. How did you find out about us?

Advertisement     Friend     Other \_\_\_\_\_  
 Catalog         Card deck

2. Do you think your machine represents good value?                      YES \_\_\_                      NO \_\_\_

3. Would you allow us to use your name as a reference for Grizzly customers in your area?                      YES \_\_\_                      NO \_\_\_  
(Note: Your name will be used a maximum of three times.)

4. To which of the following publications do you subscribe? Check all that apply.

Fine Woodworking     Popular Woodworking     FDM                       Practical Homeowner  
 American Woodworker     Fine Homebuilding     Wood & Wood Products     Home Handyman  
 Woodwork                       Workbench                       Old House Journal                       Shop Notes  
 WOOD                       Woodsmith                       Journal of Light Construction                       Cabinetmaker  
 Woodworker's Journal     Woodshop News                       Wooden Boat                       Other \_\_\_\_\_

5. What is your annual household income?

\$20,000-\$30,000                       \$60,001-\$70,000  
 \$30,001-\$40,000                       \$70,001-\$80,000  
 \$40,001-\$50,000                       \$80,001-\$90,000  
 \$50,001-\$60,000                       + \$90,000

6. To which age group do you belong?

20-30                       41-50                       61-70  
 31-40                       51-60                       +70

7. Which of the following stationary woodworking machines do you own? Check all that apply.

Table Saw                       Jointer                       Lathe                       Scroll Saw  
 Band Saw                       Planer                       Panel Saw                       Mortiser  
 Radial Arm Saw                       Drill Press                       Air Compressor & tools                       Other \_\_\_\_\_  
 Wide Belt Sander                       Shaper                       Dust Collector  
 Drum Sander                       Power Feeder                       Vacuum Veneer Press

8. How many of the machines you checked in Question 7 are Grizzly machines? \_\_\_\_\_

9. Which of the following portable woodworking machines or power tools do you own? Check all that apply.

Circular Saw                       Saber Saw                       Miter Saw                       Biscuit Joiner                      Other: \_\_\_\_\_  
 Drill/Driver                       Recipro Saw                       Belt Sander                       Orbital Sander  
 R-O Sander                       Router                       Planer                       Detail Sander

10. Which of these machines or other tools would you like Grizzly to carry? Check all that apply.

Radial Arm Saw                       Biscuit Joiner                       Combination Planer/Joiner                      Other: \_\_\_\_\_  
 Panel Saw                       Pin Router                       12" Table Saw  
 Vertical Spindle Sander                       Mortiser                       24" Planer

11. Of all the mail order woodworking companies you have purchased from, how do you rate Grizzly in terms of overall customer satisfaction?

The best                       Above average                       Average  
 Below average                       The worst

12. Comments: \_\_\_\_\_

FOLD ALONG THIS LINE

---

From:

---

---

---

PLACE  
STAMP  
HERE



GRIZZLY IMPORTS

P O BOX 2069

BELLINGHAM WA 98227-2069

---

FOLD ALONG THIS LINE

TAPE ALONG EDGES—PLEASE DO NOT STAPLE